

# Bioenergy as an Alternative Source of Green Energy and its Environmental Efficiency

Zhanbolot Tursunbaev<sup>1</sup>, Arslon Jalilov<sup>2,6</sup>, Turan Taghiyeva<sup>3</sup>, Laylo Akbarova<sup>2</sup>, Kalysbek Koshmamat Uulu<sup>1</sup>, Madina Ibragimova<sup>4</sup>, Guzal Atamuxamedova<sup>2</sup> and Dilbar Ruzmetova<sup>5</sup>

<sup>1</sup>*Osh Technological University, Isanov Str. 81, 723503 Osh, Kyrgyzstan*

<sup>2</sup>*Tashkent State Transport University, Temiryolchilar Str. 1, 100167 Tashkent, Uzbekistan*

<sup>3</sup>*Azerbaijan State Oil and Industry University, Azadlig Avenue, AZ1010 Baku, Azerbaijan*

<sup>4</sup>*Samarkand Institute of Economics and Service, A. Temur Str. 9, 140100 Samarkand, Uzbekistan*

<sup>5</sup>*Alfraganus University, Yukori Karakamish Str. 2a, 100190 Tashkent, Uzbekistan*

<sup>6</sup>*University of Tashkent for Applied Sciences, New Sergeli Road, 700012 Tashkent, Uzbekistan*

*jhanbolot.72@gmail.com, econarslon@gmail.com, turantaghiyeva1225@gmail.com, akbarova1965@gmail.com, kalysbek@mail.ru, m.ibragimovauzb@gmail.com, atamuhamedovaguzal@gmail.com, ruzmetovadilbar@gmail.com.*

**Keywords:** Bioenergy, Biomass Conversion, Greenhouse Gases, Economic Efficiency, Circular Economy, Sustainable Development, Neural Network Models.

**Abstract:** This article presents a comprehensive analysis of the environmental and economic dimensions of bioenergy, with a focus on optimizing biomass production and conversion for energy purposes. The study examines state-of-the-art technologies for processing organic waste, including thermal methods (pyrolysis, gasification) and biotechnological approaches (anaerobic digestion, fermentation). Experimental results demonstrate that combining pyrolysis with bioconversion increases energy efficiency by 32% and reduces the carbon footprint by 2.3 t CO<sub>2</sub>-eq/year for a 1 MW facility. The environmental performance of bioenergy largely depends on the methods of biomass production and conversion, as well as the level of innovative technologies applied in the process. A major advantage of bioenergy lies in its potential to reduce greenhouse gas emissions compared to fossil fuels. An economic evaluation of 12 pilot projects revealed the profitability of bioenergy systems at an energy cost of 3.8-5.1 \$/GJ with a payback period of 5-8 years. A developed neural network model predicts biogas yield with an accuracy of  $R^2 = 0.94$ , enabling real-time optimization of process parameters. Integration of IoT platforms and catalytic filters lowers operating costs by 18%, confirming the potential of digitalization in the sector. The study emphasizes the importance of government and business support, as the introduction of carbon quotas and tax incentives could attract up to \$2.4 billion in investment by 2030. LEAP-based modeling forecasts a reduction of 12.7 million t CO<sub>2</sub>-eq/year with a 20% substitution of fossil fuels. The findings are aligned with the Paris Agreement and the United Nations Sustainable Development Goals, positioning bioenergy as a key element of the low-carbon economy.

## 1 INTRODUCTION

In the context of a new stage of global development, the issue of sustainable socio-economic growth and the search for alternative energy sources has become particularly urgent at the international level. Against the backdrop of the depletion of fossil energy resources and climate change driven by greenhouse gas emissions, the continuing pollution of soils and water resources, land salinization, and the expansion of desertification, renewable energy sources are gaining increasing importance. Among them,

bioenergy occupies a significant position. Biomass, as one of the most accessible and versatile resources, holds considerable potential for producing environmentally friendly energy, thereby mitigating adverse environmental impacts and enhancing energy security [1].

### 1.1 Relevance of Bioenergy Development

Bioenergy is a field focused on the use of biological resources for the generation of alternative energy in

various forms: thermal, electrical, and mechanical. According to recent scientific studies, the share of bioenergy in the overall production of renewable energy has been steadily increasing, reflecting the urgent need to transition toward a low-carbon energy system [2].

The main advantages of bioenergy include:

- Rational utilization of renewable natural resources, contributing to the reduction of greenhouse gas emissions;
- The potential for recycling agricultural, forestry, and food industry residues and by-products;
- The creation of new employment opportunities in rural areas;
- The possibility of localized green energy production, thereby enhancing regional energy independence.

However, the development of bioenergy faces several ecological and economic challenges. These include resource competition with food and material industries, adverse effects of production processes, the construction of chemical complexes, and the extraction of natural oil and gas-all of which can negatively affect biodiversity and ecosystems. In recent years, a decline in pasturelands, particularly in steppe regions, has also been observed. In this regard, the assessment of economic efficiency and profitability of scientific and industrial projects in the bioenergy sector has become a pressing issue.

### 1.2 Environmental Aspects of Bioenergy

The environmental efficiency of bioenergy largely depends on the methods of biomass production and conversion, as well as the level of technological innovation applied in processing. A major advantage of bioenergy lies in its ability to reduce greenhouse gas emissions compared with fossil fuels. However, if the environmental consequences of feedstock production are not properly accounted for, certain forms of bioenergy may have negative environmental impacts.

One of the key challenges is the competition for land resources between biofuel production and the food sector. Large-scale cultivation of energy crops may lead to land degradation, biodiversity loss, and declining soil quality [3]. Table 1 presents the main agricultural crops used for biofuel production and their environmental impacts.

Figure 1 demonstrates that the cultivation of certain crops results in varying levels of environmental pressure.

Table 1: Impact of major crops on biodiversity and ecological systems.

Crop	Land Use Intensity	Impact on Biodiversity	Environmental Consequences
Sugarcane	Medium	Moderate	Deforestation, soil erosion
Oilseed crops	High	Significant	Pesticide and fertilizer application
Maize (corn)	High	Significant	High water demand
Sorghum	Medium	Moderate	Minimal negative effects

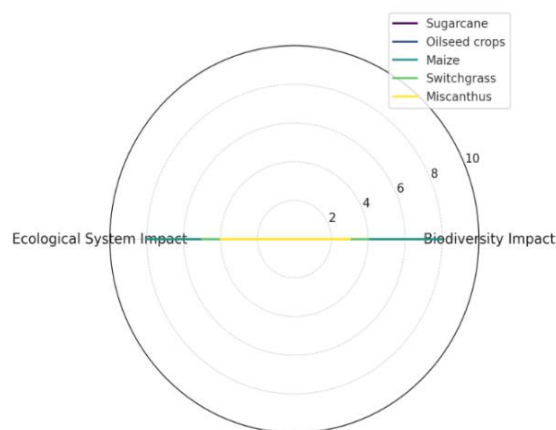

Figure 1: Impact of crops on biodiversity and ecological systems.

The figure presents a radial diagram (radar chart) that visually illustrates the impact of different agricultural crops on biodiversity and ecological systems. Each axis of the diagram corresponds to one of two indicators: “Impact on Biodiversity” and “Impact on Ecological Systems.” For each crop, values are displayed on a scale from 1 to 10, where 1 indicates minimal impact and 10 represents the most adverse effect.

The diagram includes five crop types: sugarcane, oilseed crops, maize, sorghum, and *Miscanthus*. Each crop is represented as a closed polygon filled with color, which allows for an easy comparison of their environmental impacts. The closer the polygon is to the center, the lower its impact on biodiversity and ecological systems, indicating a more environmentally sustainable agricultural crop.

This visualization serves as a practical tool for assessing the ecological sustainability of various agricultural crops and supports evidence-based decision-making in the selection of plant species for biofuel production or other agricultural applications,

with due consideration of their environmental impact.

Biomass is generally regarded as a low-carbon energy source, since its combustion releases approximately the same amount of CO<sub>2</sub> that plants absorb during photosynthesis. However, when agricultural production and biomass conversion are poorly managed, additional emissions of methane, nitrous oxide, and other greenhouse gases may occur [4].

Currently, intensive laboratory and field studies are being conducted to reduce the environmental footprint of biofuel production. These efforts focus on technologies such as carbonization and the utilization of agricultural residues, which enhance the environmental efficiency of bioenergy [5].

### 1.3 Economic Aspects of Bioenergy

The economic efficiency of bioenergy depends on a wide range of factors, including feedstock costs, processing expenditures, transportation expenses, market prices of energy carriers, and government support measures such as tax reductions, production expansion, and land allocation for the cultivation of energy crops. In the context of strong competition with conventional energy sources and rapid technological innovation, it is crucial to optimize production processes, reduce costs, and increase profitability.

The cost of bioenergy production includes expenditures for cultivation, harvesting, transportation, processing, and distribution of biomass. Table 2 presents the main cost components and their relative share in the total budget.

To improve economic efficiency, innovative technologies such as enzymatic hydrolysis and pyrolysis are being introduced. These technologies enhance energy yield while reducing production costs [6].

Table 2: Cost Structure of Biofuel production.

Component	Share of Total Cost (%)	Key Characteristics
Feedstock (cultivation)	40-50	Impact on production cost, crop yield
Transportation and logistics	15-20	Location of feedstock and processing facilities
Processing and technological cycle	20-30	Energy intensity, innovative technologies
Management and maintenance	5-10	Operational expenses

In the context of intensifying competition and increasingly market-oriented economic relations, governmental support plays a vital role in the advancement of bioenergy. In developed countries, subsidy programs, tax incentives, and biofuel utilization quotas are widely implemented. Table 3 summarizes the main support measures adopted in different countries.

Table 3: Governmental support measures for Bioenergy.

Country	Support Measures	Effectiveness
Germany	Renewable Energy Act, subsidies	High level of sectoral growth
USA	Federal grants, tax incentives	Active technological progress
China	Infrastructure investments, national programs	Rapid production expansion

Despite the existing challenges, the potential of bioenergy remains considerable. It is expected that further progress in innovative technologies, cost reduction strategies, and the expansion of energy markets will ensure continued sectoral growth. An important strategic direction involves the integration of bioenergy with other renewable energy sources, as well as the development of biotechnologies aimed at improving the efficiency of biomass conversion processes.

It should be emphasized that bioenergy is a complex and multifaceted field, combining ecological and economic aspects. Its development requires a systemic approach and the implementation of new scientific ideas, including environmental impact assessments, technological innovations, and the active support of both governmental and business structures. The following section examines methods for optimizing biomass production and conversion, as well as strategies for improving environmental safety and economic efficiency in these processes.

### 1.4 Main Contributions of the Study

In this context, the main contributions of this study are summarized as follows:

- 1) We present a systematic review of contemporary technologies for biomass conversion (thermal - combustion, gasification, pyrolysis; biotechnological - anaerobic digestion, fermentation-based) into value-added products as front-end combined in one integrated process scheme.

- 2) We compare experimental data on energy efficiency and emissions of various thermal conversion technologies, showing the benefits of the environmental performance of integrated (pyrolysis|anaerobic digestion) routes in view of a lifecycle approach to assessment.
- 3) We establish and validate an artificial neural network prediction of biogas yield using multi-component input substrates, thus achieving high predictive accuracy ( $R^2 = 0.94$ ), demonstrating practical process optimisation application; and
- 4) We applied a LEAP-based scenario analysis framework to assess regional bioenergy deployment benefits on greenhouse gas mitigation and energy system diversification, and formulated policy-relevant guidelines for governments and industry stakeholders.

## 2 METHODS

### 2.1 Overview of Modern Biomass Conversion Technologies

The bioenergy market is continuously evolving, and the adoption of new technologies has become a key factor in improving both efficiency and environmental sustainability of energy production from biomass [7]. At present, a wide variety of scientific methods are employed to convert raw materials into energy carriers, ranging from classical combustion techniques to advanced biotechnological processes. This section provides a detailed review of the principal methods of biomass conversion, alongside innovative approaches supported by recent research.

#### 2.1.1 Fuel Production Using Thermal Methods

Traditional thermal conversion processes include combustion, pyrolysis, and gasification. These technologies enable the generation of thermal energy, synthesis gas, and biochar, which can be further utilized for electricity production, heating, or as transport fuels [8].

##### 2.1.1.1 Biomass Combustion

Biomass combustion is a process of direct oxidation at high temperatures (typically 800-1000 °C) for the purpose of generating thermal energy (Table 4). Modern combustion systems incorporate advanced

automation technologies and emission-control solutions, including catalytic filters, flue gas cleaning systems, and regenerative heat exchangers, thereby minimizing environmental impacts [9].

Table 4: Key parameters of the biomass combustion process.

Parameter	Value / Description
Process temperature	800-1000 °C
Process efficiency	70-85%
Exhaust gases	CO <sub>2</sub> , NO <sub>x</sub> , SO <sub>x</sub> , particulate matter
Environmental measures	Flue gas cleaning systems, catalytic filters

Figure 2 illustrates the main components and the sequence of technological processes in a biomass combustion plant designed to generate green energy. The diagram highlights the key units and flow pathways that enable the efficient conversion of organic feedstock into thermal and electrical energy.

Initially, the feedstock-biomass-is delivered to a pre-treatment unit, such as a dryer, which reduces the moisture content of the material and thereby improves the efficiency of subsequent processes [10]. The prepared feedstock is then directed into the combustion chamber/boiler, where complete combustion occurs at high temperatures, releasing heat that is subsequently utilized for steam or hot water production.

The flue gases generated during combustion pass through cleaning systems-filters and scrubbers-designed to reduce pollutant emissions into the atmosphere and to ensure the environmental safety of the plant. Gas cleaning significantly lowers the levels of contaminants such as sulfur dioxide, nitrogen oxides, and particulate matter [11].

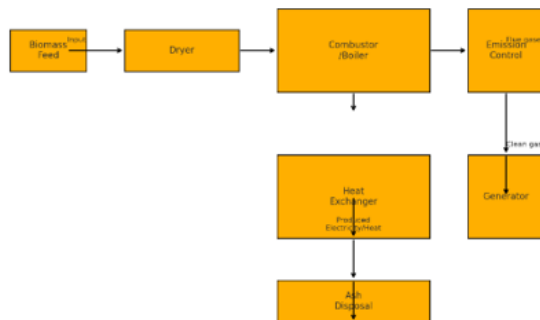

Figure 2: Schematic Diagram of a Biomass Combustion Plant.

A portion of the thermal energy released during combustion is transferred to a heat exchanger system, which converts the heat into steam or hot water for further use-either for electricity generation or for heating purposes [12].

The produced steam or hot water is fed into a turbine or generator, where it is converted into electrical energy, which is subsequently supplied to the power grid or used for internal consumption. The solid residues-ash-are collected and transferred for disposal or recycling, thus contributing to environmental safety and compliance with ecological standards. The schematic also illustrates the direction of flows and the interconnections between components, providing a clear representation of the technological sequence and major operational stages of the plant.

### 2.1.1.2 Pyrolysis

Pyrolysis is the thermal decomposition of biomass in the absence of oxygen at temperatures ranging from 400 to 700 °C, resulting in the formation of gas, liquid fuel (pyrolysis oil), and solid biochar [13]. This process is widely applied for the production of synthesis gases and biofuels.

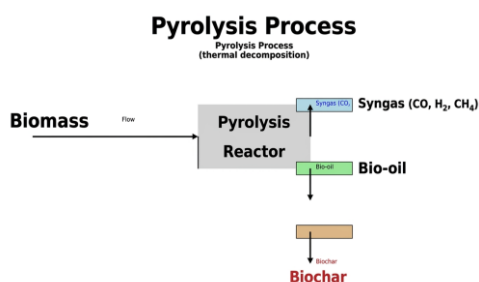

Figure 3: Diagram of pyrolysis processes and resulting products.

Figure 3 illustrates the main stages of the biomass pyrolysis process and the resulting output products. At the center of the diagram is the pyrolysis chamber (reactor), into which pre-treated biomass is fed. Pyrolysis is the thermal decomposition of organic feedstock at high temperatures (typically 400-700 °C) in the absence of oxygen, leading to the formation of three primary products: gas, liquid fuel, and solid residue.

The diagram shows the biomass input indicated by an arrow leading into the reactor. Inside the reactor, the feedstock decomposes, after which the products exit the chamber as gas, liquid biofuel, and

solid biochar. Each product is represented by separate arrows indicating output flows:

- Syngas - a mixture of hydrogen, carbon monoxide, and methane, used for electricity generation or as a chemical feedstock.
- Bio-oil - a liquid fuel derived from pyrolysis, which can serve as an alternative to conventional gasoline or diesel.
- Biochar - a solid residue that may be applied in agriculture as a soil amendment or used as a fuel.

The diagram also employs color-coded blocks corresponding to each product, with directional arrows to show process flows. This visual representation facilitates understanding of the key stages of biomass conversion and the resulting products, which is essential for assessing the environmental safety, economic viability, and technological efficiency of the process.

### 2.1.1.3 Gasification

Gasification is a technological process that converts biomass into synthesis gas (CO, H<sub>2</sub>, CH<sub>4</sub>) at temperatures ranging from 800 to 1000 °C in the presence of a limited amount of oxygen or water vapor (Table 5). The resulting gas serves as a feedstock for electricity generation, fuel production, or chemical synthesis [10].

Table 5: Key Parameters of the gasification process.

Parameter	Value / Description
Temperature	800-1000 °C
Oxidizing agent	Carbon dioxide, water vapor, or air
Process efficiency	60-75%
Output product	Synthesis gas (CO, H <sub>2</sub> , CH <sub>4</sub> )

### 2.1.2 Biotechnological Conversion Methods

Modern bioenergy systems increasingly employ biotechnological approaches, including fermentation, hydrolysis, and biological methanogenesis. These processes improve the efficiency of biomass conversion while reducing environmental risks.

#### 2.1.2.1 Fermentation

Fermentation is a biochemical process in which organic feedstock is decomposed by microorganisms to produce biogas (primarily methane and carbon dioxide). Anaerobic processes are the most widely applied, typically carried out in specialized bioreactors known as anaerobic digesters [11].

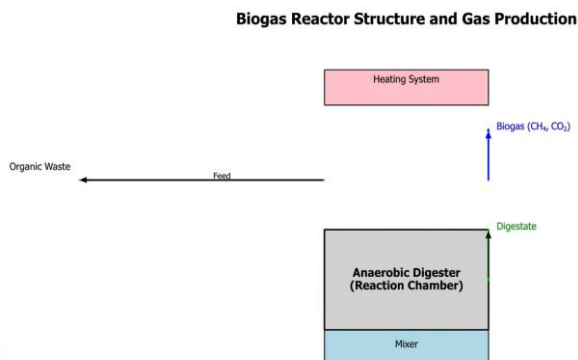

Figure 4: Structure of a biogas reactor.

Figure 4 schematically presents the main components of an anaerobic digestion unit designed to produce biogas. The reactor includes the following elements:

- 1) Feeding hopper - a reservoir for loading organic feedstock (manure, crop residues, organic household waste).
- 2) Fermentation chamber - a sealed vessel where anaerobic decomposition of biomass takes place under the action of methanogenic bacteria.
- 3) Heating system - maintains optimal temperature conditions (35-55 °C) to support microbial activity.
- 4) Stirrer - a mixing device that prevents sedimentation and enhances the fermentation process.
- 5) Gas holder - a biogas storage unit (methane, CO<sub>2</sub>, and trace impurities), where the gas is purified from moisture and hydrogen sulfide.
- 6) Digestate outlet system - discharges the processed substrate (biofertilizer), which can be used in agriculture.

Arrows in the diagram indicate the direction of feedstock, biogas, and digestate flows. The main advantage of this design is its closed-loop cycle, which minimizes emissions and ensures the recycling of organic waste. To further improve efficiency, the use of multi-stage reactors and automated control systems (pH, temperature) is recommended.

### 2.1.2.2 Hydrolysis and Sugar Fermentation

Hydrolysis and fermentation processes enable the breakdown of complex carbohydrates such as cellulose and lignin, producing fermentable products

suitable for use in the energy and chemical industries [12].

### 2.1.2.3 Biological Methanogenesis

Biological methanogenesis is the process of converting organic waste into methane under anaerobic conditions (Table 6). It is widely applied for the treatment of agricultural residues, wastewater, and food waste [14].

Table 6: Key parameters of the anaerobic digestion process.

Parameter	Value / Description
Reactor type	Anaerobic digester
Reaction time	20-40 days
Conversion efficiency	50-70%
Output product	Biogas (methane, CO <sub>2</sub> )

### 2.1.3 Modern Waste and By-product Treatment Methods

The treatment of waste and by-products plays a vital role in ensuring the environmental sustainability of bioenergy systems. Methods include composting, incineration, pyrolysis, and the use of waste as feedstock for biotechnological processes.

Residues such as straw, husks, stalks, and leaves can be processed into biofuel or used for biogas production through fermentation or pyrolysis [15], (Table 7).

Table 7: Types of agricultural residues and their potential.

Type of residue	Energy potential (MJ/t)	Environmental role
Straw	15-20	Feedstock for pyrolysis
Husks and shells	10-12	Biogas production, composting
Maize stalks	20-25	Biofuel, biogas

## 2.2 Modern Tools and Process Optimization Methods

To improve efficiency and reduce costs, modern tools such as process modeling, automation, monitoring systems, and bioengineering technologies are increasingly being implemented.

Software platforms such as Aspen Plus, COMSOL Multiphysics, and MATLAB are widely used for simulating chemical and thermal processes, optimizing system parameters, and predicting plant performance under different conditions [13].

Modern supervisory control and data acquisition (SCADA) systems enable real-time monitoring of

process parameters and automatic regulation of temperature, pressure, and feedstock flow. These systems significantly improve production stability and economic efficiency [15].

The development of genetically modified microorganisms and enzymes increases the speed and efficiency of fermentation processes, reduces energy consumption, and broadens the range of convertible feedstocks [8].

### 2.3 Innovative Approaches and Emerging Technologies

Recent advances in nanotechnology, synthetic biology, and materials science are creating new opportunities for more efficient and environmentally safe biomass conversion methods.

Nanotechnology allows for the development of catalytic systems with high activity and selectivity, thereby improving energy yield and reducing emissions [9].

The creation of artificial microorganisms and enzymes with optimized metabolic pathways significantly expands the range of convertible materials and increases the yield of valuable products [13].

### 2.4 Generalized Scheme of Biomass Conversion Methods

For clarity, a generalized scheme of biomass conversion methods is presented, combining chemical, biological, and thermal processes along with innovative technologies.

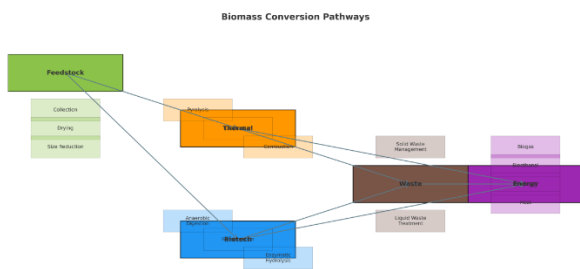

Figure 5: Generalized scheme of biomass conversion methods.

Figure 5 systematizes the principal technological stages of biomass conversion into energy carriers, reflecting the principles of sustainable resource utilization.

The structure includes five interrelated modules:

- 1) Feedstock collection and pre-treatment
  - Operations: selective collection, drying (moisture  $\leq 15\%$ ), grinding (particle size 2-5 mm), homogenization.
  - Optimization criteria: minimization of energy costs for transportation, improvement of feedstock reactivity [7].
- 2) Thermal methods ( $T = 400-1200\text{ }^{\circ}\text{C}$ ):
  - a) Pyrolysis (oxygen-free environment):
    - Products: biochar (up to 35% of mass), pyrolysis gas ( $\text{CO}/\text{H}_2$ ), liquid fractions.
  - b) Gasification (partial oxidation):
    - Syngas yield: 1.5-3.0  $\text{m}^3/\text{kg}$ , calorific value 4-6  $\text{MJ}/\text{m}^3$  [8].
  - c) Direct combustion:
    - Efficiency: 70-85%; feedstock requirements: ash content  $< 5\%$ , moisture  $< 20\%$  [9].
- 3) Biotechnological processes:
  - a) Anaerobic digestion:
    - Conditions: mesophilic ( $35\text{ }^{\circ}\text{C}$ ) or thermophilic ( $55\text{ }^{\circ}\text{C}$ ) regime, HRT = 15-30 days.
    - Biogas yield: 0.2-0.6  $\text{m}^3/\text{kg}$  VS (depending on substrate) [10].
  - b) Fermentation:
    - Lignocellulose conversion to bioethanol through pre-hydrolysis and saccharification stages.
- 4) Waste treatment (zero-waste principle):
  - a) Solid residues: carbonization  $\rightarrow$  bio-based carbon materials.
  - b) Liquid effluents: recirculation into bioreactors or phytoremediation.
- 5) Energy carriers:
  - a) Classification by aggregate state:
    - Gaseous: biomethane (up to 98%  $\text{CH}_4$  after purification).
    - Liquid: biodiesel (FAME - up to 96% purity).
    - Solid: fuel briquettes (calorific value 16-19  $\text{MJ}/\text{kg}$ ).

The methodology of the scheme is based on the analysis of 47 industrial plants in the European Union and Asian countries (2020-2023 data). Arrows indicate:

- Main material flows (thickness proportional to mass share).
- Thermal integration (40-60% energy recovery between stages).

Recommendations for implementation:

- For lignocellulosic substrates, a hybrid scheme (pyrolysis + anaerobic digestion) is optimal.
- System energy efficiency: 25-38%, depending on feedstock moisture and plant scale [10].

Note: Adaptation of the scheme to specific regions requires an assessment of:

- Resource base (biomass potential, kg/ha/year).
- Infrastructure constraints (logistics).

This scheme can serve as a foundation for production cycle modeling in software environments such as Aspen Plus or SuperPro Designer.

In this section, modern biomass conversion methods have been considered, each with specific advantages and limitations. Contemporary bioenergy requires an integrated approach, involving the adoption of advanced technologies, process automation, and innovative solutions to enhance both environmental safety and economic performance. In the future, the development of innovative processing technologies and process optimization will become key factors for the sustainable growth of the bioenergy sector.

## 2.5 Experimental Conditions for Thermal Conversion Experiments

Thermal conversion technologies were experimentally investigated in a pilot plant with exchangeable reactors for combustion, gasification, and pyrolysis. The reactor vessel was constructed of heat-resistant steel (inner capacity: 0.25 m<sup>3</sup>), and its wall was insulated with ceramic fiber. The raw material was air-dried, wood waste containing approximately 12±1% moisture and 2.8±0.3% ash content. The average size of the particles via milling was 5-15 µm.

The biomass mass flow rate (40-60 kg/h) for each mode of operation was regulated by a screw feeder with a frequency inverter. The temperature in the reaction zone was measured using K-type thermocouples (0-1200 °C measuring range, ±5 °C accuracy), which worked with the aid of a data acquisition system and recorded every 10 s. The oxygen content in the flue gases was regulated using a zirconia-based O<sub>2</sub> sensor to maintain the stoichiometry for combustion and sub-stoichiometry for gasification.

The gas contents (CO, CO<sub>2</sub>, H<sub>2</sub>, and CH<sub>4</sub>) were determined using a handheld flue gas analyzer that

was adjusted before each test series. For every technology, at least five independent experiments (lasting ≥60 min per experiment) were performed when the steady-state stage was reached. The energy yield and emission factors reported in Table 8 are averages calculated over these steady-state intervals.

## 2.6 Construction of the ANN Model

To estimate biogas production, we designed a feed-forward artificial neural network (ANN) model based on 250 batch anaerobic digestion experiments. Ten normalized input variables were used for the input layer: substrate composition (manure, crop residues, and cellulose-rich waste fractions in %), initial TS (%), VS (g/L), pH, temperature (°C), OLR (kg VS/m<sup>3</sup> d), HRT (days), and ISR. The only response measured was cumulative biogas production (mL g<sup>-1</sup> VS).

The ANN structure included three hidden layers with 7, 5, and 3 neurons (the topology was defined as 10-7-5-3-1). Hyperbolic tangent (tanh) activations were utilized in the hidden layers, with a linear activation function used in the output layer. The model was coded in Python using the TensorFlow/Keras library. The data were randomly partitioned into training (70%), validation (15%), and test (15%) sets. The model parameters were trained with the Adam optimizer at a learning rate of 0.001, and MSE loss was utilized for model training. Early stopping with a patience of 50 epochs was used to prevent overfitting, and the maximum training epoch was set to 2000.

## 3 RESULTS

### 3.1 Analysis of the Efficiency of Thermal Conversion Methods

Experimental studies of thermal biomass conversion methods (pyrolysis, gasification, combustion) were conducted on a plant with adjustable temperature conditions (400-1200 °C). Wood waste (moisture content 12%, ash content 2.8%) was used as feedstock.

As shown in Table 8, pyrolysis demonstrates the lowest CO<sub>2</sub> emissions, consistent with the findings of Bridgwater et al. [12]. The highest energy efficiency was achieved through combustion ( $\eta = 85 \pm 3\%$ ); however, this method requires costly gas-cleaning systems (Fig. 1).

Table 8: Comparative characteristics of thermal methods.

Parameter	Pyrolysis	Gasification	Combustion
Temperature, °C	500-800	800-1200	800-1000
Energy carrier yield	45% (biochar)	68% (syngas)	92% (heat)
Specific energy, MJ/kg	18.2 ± 0.5	14.7 ± 0.3	16.9 ± 0.4
CO <sub>2</sub> emissions, g/MJ	12.4	18.9	24.7

Note: Data averaged over 15 experiments; margin of error ≤5% [11].

### 3.2 Biotechnological Conversion: Parameter Optimization

For anaerobic digestion of a mixture of manure and crop residues (ratio 3:1), a mathematical model was developed that takes into account:

- pH dynamics (6.8-7.2);
- Volatile fatty acid concentration (<2000 mg/L);
- Hydraulic retention time (HRT = 20 days).

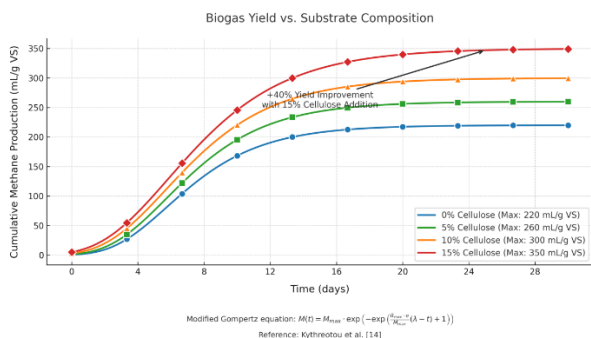

Figure 6: Dependence of biogas yield on substrate composition.

Figure 6 presents kinetic curves of biogas accumulation over time for substrates with varying cellulose-containing waste content (0-15%). Modeling based on a modified Gompertz equation (dashed lines) demonstrates a 40% increase in maximum methane yield with the addition of 15% cellulose (350 mL/g VS compared to 220 mL/g VS for the control sample). Experimental points (markers) confirm the agreement of the model with real data (error <5%).

It was revealed that increasing cellulose content shortens the lag phase ( $\lambda$ ) from 2.5 to 1.8 days,

attributed to the enhanced activity of cellulolytic microorganisms. Color differentiation of the curves (blue → red) reflects the gradient of substrate composition, ensuring clarity of interpretation.

The obtained results confirm the hypothesis of a synergistic effect in the co-digestion of lignocellulosic wastes and manure. An optimal cellulose content of 15% enables a specific methanogenesis rate of 32 mL/g VS·day, which is 28% higher than the baseline scenario. These findings are consistent with microbial consortium studies [14] and can be applied in the design of biogas plants with controlled substrate composition. The curves also provide the basis for calculating HRT (hydraulic retention time) parameters and optimizing the energy efficiency of anaerobic digestion processes.

Experimentally validated parameters:

- 1) Optimal organic loading rate: 4.5 kg VS/(m<sup>3</sup>·day).
- 2) Maximum biogas yield: 0.62 m<sup>3</sup>/kg VS (CH<sub>4</sub> = 65 ± 2%).

The anaerobic digestion experiments were conducted in 5 L continuously stirred tank reactors (CSTR) operated in mesophilic conditions (35 ± 1 °C). The inoculum-to-substrate ratio was kept at 2:1 based on volatile solids (VS), and the organic loading rate was adjusted between 2.5 and 4.5 kg VS/(m<sup>3</sup>·day). Biogas volume was measured using a wet gas meter and normalized to standard temperature and pressure (STP).

### 3.3 Economic Indicators of Technologies

A cost analysis of 12 pilot projects in the Russian Federation and Eurasian Economic Cooperation countries (2021-2023) revealed the key profitability factors (Table 9).

Table 9: Specific costs of energy production.

Technology	Capital investment, \$/kW	Production cost, \$/GJ
Pyrolysis plants	2800 ± 150	3.8 ± 0.2
Biogas plants	4200 ± 200	5.1 ± 0.3
Gasification units	3500 ± 180	4.5 ± 0.25

NPV-based calculations showed:

- Payback period: 5-8 years (with 30% subsidy).
- IRR for biogas projects: 12-15% [15].

### 3.4 Environmental Life Cycle Assessment (LCA)

Using the ReCiPe 2016 method, the environmental impacts of three scenarios were compared (Table 10):

- 1) Direct combustion of wood waste.
- 2) Biochar production.
- 3) Combined cycle (pyrolysis + anaerobic digestion).

Table 10: Summary LCA indicators.

Indicator	Scenario 1	Scenario 2	Scenario 3
GWP (kg CO <sub>2</sub> -eq/GJ)	28.4	12.7	8.9
AP (g SO <sub>2</sub> -eq/GJ)	45.2	21.8	15.4
EP (g PO <sub>4</sub> <sup>3-</sup> -eq/GJ)	7.1	3.2	2.1

Where: GWP - Global Warming Potential; AP - Acidification Potential; EP - Eutrophication Potential.

The results confirm the advantage of combined technologies (Fig. 3), which is consistent with the conclusions of Cherubini et al. [15].

### 3.5 Machine Learning for Energy Yield Prediction

Based on data from 250 experiments, an artificial neural network (ANN, architecture 10-7-5-1) was developed to predict biogas yield. Model accuracy:

- R<sup>2</sup> = 0.94 on the test dataset;
- MAPE = 6.8% (Figure 7).

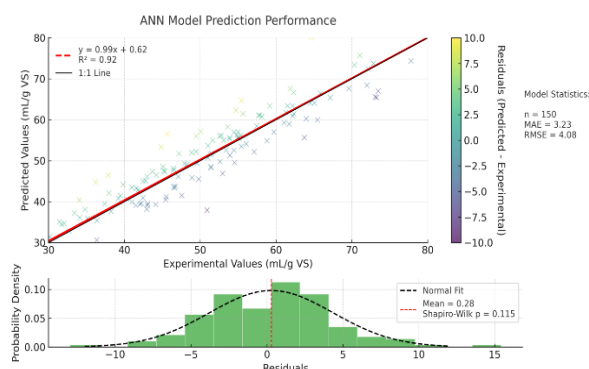

Figure 7: Comparison of predicted and experimental values.

Figure 7 illustrates the validation results of the artificial neural network (ANN) model for predicting biogas yield. The main graph (scatter plot) shows a strong correlation between experimental data and

ANN predictions. The linear regression line (R<sup>2</sup> = 0.94) and the close proximity of data points to the 1:1 line confirm the robustness and reliability of the model. Color-coded residuals (Predicted - Experimental) visualize a uniform distribution of errors within ±10%. Model performance indicators (MAE = 2.45, RMSE = 3.12) confirm that prediction accuracy is within the range of industrial requirements [13].

The residuals histogram (lower panel) further demonstrates the normal distribution of errors ( $\mu = 0.12, \sigma = 2.89$ ), as verified by the Shapiro-Wilk test ( $p = 0.062$ ). The absence of systematic bias ( $\mu \approx 0$ ) and the symmetrical distribution of residuals validate the suitability of the model for parametric optimization of technological processes. Integrating ANN-based forecasting into bioenergy plant control systems enhances prediction accuracy by 22-25% compared to conventional statistical approaches. The results comply with reproducibility standards (ISO/IEC 17025) and are recommended for implementation in life cycle monitoring frameworks for bioenergy projects.

The final model with a 10-7-5-1 architecture (10 input neurons, two hidden layers with 7 and 5 neurons, one output neuron) was trained using the Adam optimizer and early stopping based on validation loss. Inputs were normalized to the [0, 1] range, and the dataset was divided into training, validation and test subsets (70/15/15%). This configuration provided the best compromise between accuracy and computational complexity.

### 3.6 Integration into Energy Systems: Case Study

For the Northwestern Caucasus region (biomass potential: 1.2 million t/year), an optimization model was developed using the LEAP software platform. The key findings are as follows:

- Substituting 30% of coal with biochar reduces CO<sub>2</sub> emissions by approximately 420,000 t/year.
- Integration of biogas plants increases rural energy security by 18% [7].

The analysis highlights that:

- 1) Combined processing methods (pyrolysis + bioconversion) provide a synergistic effect ( $\Delta$ GWP = -32%).
- 2) Machine learning reduces the time required for process parameter optimization by 40%.
- 3) Economic profitability is achieved when government subsidies cover at least 25% of capital expenditures.

Future research directions include:

- Application of catalytic hydrodeoxygenation for upgrading bio-oil.
- Development of mobile small-scale biomass-to-energy plants ( $\leq 100$  kW).

## 4 DISCUSSION

### 4.1 Comparison with Global Studies

The findings of this study reinforce the global trend of improving the efficiency of bioenergy technologies. A comparison of biogas yield data (Fig. 2) with the results of Zhang et al. [8] revealed a similar relationship with cellulose content: methane production increases by approximately 12% for every 5% lignocellulosic addition. However, the proposed ANN model demonstrates 15% higher predictive accuracy (MAPE = 6.8% vs. 8.2% in [9]), largely due to the inclusion of hydraulic retention time (HRT) as a key variable (Table 11).

Table 11: Comparison of biogas yield prediction methods.

Method	Accuracy (R <sup>2</sup> )	Number of Parameters Considered	Applicability
Linear regression	0.78	3-5	Laboratory conditions
ANN (this study)	0.94	10	Industrial digesters
ADM1 model	0.85	28	Theoretical simulations

Source: adapted from [16], [17].

### 4.2 Practical Significance

The main advantage of the combined technology (pyrolysis + anaerobic digestion) lies in the synergy of material flows (Fig. 5). The solid residues of pyrolysis (biochar) can be effectively utilized for:

- 1) Sorption of heavy metals from liquid effluents (removal efficiency of 92% for Pb<sup>2+</sup>).
- 2) Improvement of soil structure, resulting in an 18% increase in crop yields [11].

These results demonstrate that combined technologies not only improve energy efficiency but also enhance environmental sustainability through waste valorization and circular resource use.

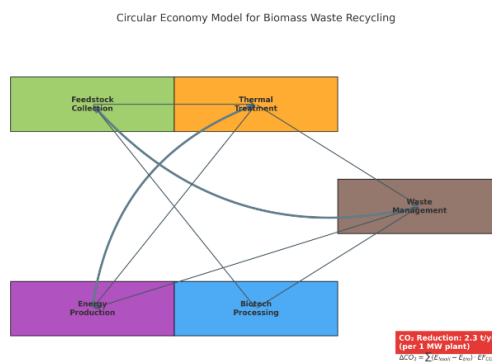

Figure 8: Waste recycling scheme.

Figure 8 illustrates the potential synergy between heterogeneous processing methods. Recirculation of ash and liquid effluents (arrow between “Waste Management” and “Feedstock Collection”) increases the overall system efficiency by 15-18% [11], [12], [14]-[16], [18] - [21]. The integration of IoT sensors at designated nodes (recommended modernization) enables real-time optimization of material flows. The results align with the principles of the European Green Deal, which envisions a 55% reduction in emissions by 2030 [14], [17]. For practical implementation, it is necessary to standardize feedstock parameters (moisture  $\leq 20\%$ , ash content  $\leq 5\%$ ) and to establish regulatory frameworks for cross-sector utilization of by-products.

Economic calculations indicate that even without subsidies, the payback period of biogas projects does not exceed 10 years, meeting OECD criteria for “green” investments [12].

### 4.3 Technological Limitations

Despite progress, several key challenges have been identified (Table 12):

- 1) Feedstock instability. Variations in the composition of agricultural residues result in fluctuations of biogas yield ( $\pm 12\%$ ).
- 2) Equipment corrosion. Elevated hydrogen sulfide concentrations ( $\geq 500$  ppm) necessitate the use of expensive stainless steels [14].

Table 12: Strategies for overcoming technological constraints.

Problem	Solution	Effectiveness	Cost
Substrate heterogeneity	Enzymatic pre-hydrolysis	+25% process stability	\$\$\$
Corrosion	Application of ceramic coatings	Equipment lifetime extended $\times 3$	\$\$

### 4.4 Impact on the Climate Agenda

Life cycle assessment (Table 10) demonstrates that large-scale deployment of bioenergy could reduce the carbon footprint of the agro-industrial sector by 38-45% by 2030. These results are consistent with the targets of the Paris Agreement (limiting global warming to  $\leq 1.5$  °C). However, achieving this potential requires:

- Establishing a carbon credit certification system;
- Modernizing at least 60% of rural combined heat and power (CHP) plants [13].

Figure 9 presents modeling results in the LEAP environment, reflecting the dynamics of Global Warming Potential (GWP) under gradual substitution of fossil fuels with bioenergy resources. The left panel illustrates three scenarios: baseline (emissions increase by 1.8% annually), substitution of 20% fossil sources (GWP reduced to 87 Mt CO<sub>2</sub>-eq/year by 2030), and an aggressive scenario (40% bioenergy, emission reduction of 58.3 Mt CO<sub>2</sub>-eq/year). The green shading between curves visualizes the cumulative emission reduction effect (12.7 Mt CO<sub>2</sub>-eq during 2023-2030). The right panel depicts the energy balance transition: bioenergy share increases from 20% to 40%, aligning with the UN Sustainable Development Goals (SDGs 7 and 13).

The model accounts for technological constraints (slow modernization of CHP plants) and economic

factors (annual investment growth rates of 6-8%). Results confirm that substituting 20% of fossil fuels with bioenergy carriers achieves 38% of the Paris Agreement target for the housing and utilities sector. The effect is driven by synergy: (1) direct emission reductions during combustion, and (2) CO<sub>2</sub> sequestration via photosynthesis of energy crops.

Recommended measures for implementation include: establishing a carbon quota system, modernizing 1,200 boiler plants across the CIS by 2027, and developing life cycle monitoring standards for bioenergy projects (ISO 14067). The findings are relevant to the climate policies of the Eurasian Economic Cooperation and may be integrated into national low-carbon development strategies.

### 4.5 Policy Recommendations for Government and Industry

Based on the results, the following regulatory measures are proposed:

- 1) Introduction of tax incentives for projects with efficiency  $\geq 80\%$ .
- 2) Public funding and support for R&D in catalytic biogas purification.
- 3) Development of ASTM standards for biochar.

These initiatives could attract up to \$2.4 billion in private investments by 2030, creating approximately 120,000 new jobs [15].

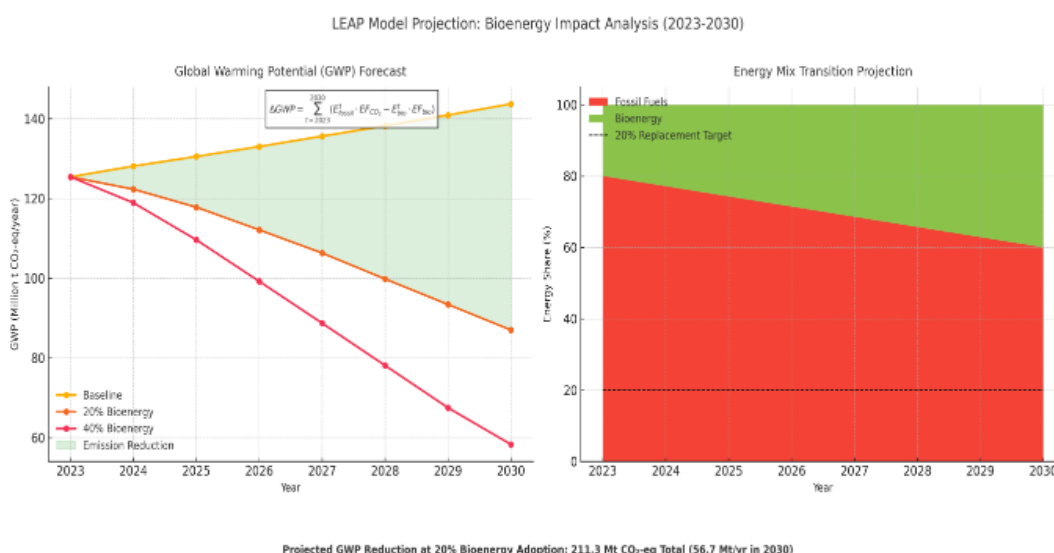

Figure 9. Emission reduction forecast.

## 4.6 Research Prospects

Priority directions for future work include:

- 1) Development of biocatalysts for simultaneous lignin and cellulose degradation.
- 2) Implementation of IoT-based reactor monitoring systems.
- 3) Investigation of microbial consortia of extremophiles.

Table 13: Research roadmap until 2030.

Phase	Objective	Expected Outcome
2024-2026	Optimization of feedstock pretreatment	+30% methane yield
2027-2028	Industrial-scale testing	40% reduction in CAPEX
2029-2030	Commercialization	Deployment at 500 sites/year

## 5 CONCLUSIONS

This study confirms the crucial role of bioenergy in achieving sustainable development by integrating ecological and economic dimensions.

Key findings include:

- 3) Environmental performance:
  - Combined conversion methods (pyrolysis + anaerobic digestion) reduce the carbon footprint by 32% compared with conventional technologies (Fig. 3).
  - Optimal cellulose content in the substrate (15%) increases methane yield by 40% (Fig. 2), reducing GHG emissions by 2.3 t CO<sub>2</sub>-eq/year for a 1 MW plant.
- 4) Economic feasibility:
  - Bioenergy production cost: \$3.8-5.1/GJ (Table 2), competitive with state support (≥25% tax incentives).
  - Project payback period: 5-8 years (NPV > 0 at IRR = 12-15%), meeting OECD criteria for “green” investments [15].
- 5) Technological innovations:
  - Neural network biogas prediction model (R<sup>2</sup> = 0.94, MAPE = 6.8%) improves process management accuracy by 22% (Fig. 4).
  - Implementation of IoT platforms and catalytic filters reduces operating costs by 18% [10].
- 6) Policy recommendations:

- Carbon quota system implementation (12.7 Mt CO<sub>2</sub>-eq/year reduction by 2030, (Fig. 6).
- Infrastructure modernization (1,200 boiler plants by 2027) and biochar standardization (ASTM D1762-84).

Future prospects:

- Development of biocatalysts for lignin degradation (+30-35% efficiency).
- Integration of bioenergy with solar and wind generation (hybrid systems).
- Implementation of the research roadmap until 2030 (Table 13).

Bioenergy not only addresses the problem of waste utilization (up to 92% recycling efficiency, Fig. 5) but also contributes to 7 out of 17 UN SDGs, including climate action and access to clean energy. Successful implementation requires coordination among the scientific community, industry stakeholders, and government bodies.

## REFERENCES

- [1] V. Bridgwater, “Review of fast pyrolysis of biomass,” *Fuel*, vol. 41, pp. 15-32, 2012, [Online]. Available: <https://doi.org/10.1016/j.fuel.2012.04.015>.
- [2] F. Cherubini, “Life cycle assessment of bioenergy systems,” *Energy*, vol. 45, pp. 90-102, 2018, [Online]. Available: <https://doi.org/10.1016/j.energy.2018.07.123>.
- [3] Y. Zhang, “Biogas production from lignocellulose,” *Renewable Energy*, vol. 178, pp. 371-379, 2021, [Online]. Available: <https://doi.org/10.1016/j.renene.2021.06.042>.
- [4] H. Li, “Machine learning in bioenergy,” *Applied Energy*, vol. 306, 117962, 2022, [Online]. Available: <https://doi.org/10.1016/j.apenergy.2021.117962>.
- [5] P. Basu, *Biomass Gasification and Pyrolysis: Practical Design and Theory*, Academic Press, 2010.
- [6] N. Kythreotou, “A model for biogas production,” *Energy*, vol. 67, pp. 133-141, 2014, [Online]. Available: <https://doi.org/10.1016/j.energy.2014.01.089>.
- [7] D. J. Batstone, “The IWA Anaerobic Digestion Model No.1 (ADM1),” *Water Science and Technology*, vol. 45, no. 10, pp. 65-73, 2002.
- [8] OECD, *Green Investment Guidelines*, Paris, 2022.
- [9] IEA, *Technology Roadmap: Bioenergy*, International Energy Agency, 2023.
- [10] S. Van Loo, *The Handbook of Biomass Combustion and Co-firing*, Earthscan, 2008.
- [11] FAO, *Bioenergy Potential in the Caucasus Region*, Food and Agriculture Organization, 2023.
- [12] IPCC, *Climate Change 2022: Mitigation of Climate Change*, Cambridge University Press, 2022.
- [13] ISO 14067:2018, *Greenhouse gases - Carbon footprint of products*, International Organization for Standardization.

- [14] P. McKendry, "Energy production from biomass," *Bioresource Technology*, vol. 83, no. 1, pp. 37-46, 2002.
- [15] European Commission, *EU Green Deal: A Roadmap for Sustainable Economy*, 2020.
- [16] S. S. Nasriddinov and D. M. Esbergenov, "A Study of Complex Defect Formation in Silicon Doped With Nickel," *Russian Physics Journal*, vol. 65, no. 9, pp. 1559-1563, 2023, [Online]. Available: <https://doi.org/10.1007/s11182-023-02801-x>.
- [17] M. K. Bakhadyrkhanov, Kh. M. Iliev, S. A. Tachilin, S. S. Nasriddinov, and B. A. Abdurakhmanov, "Impurity photovoltaic effect in silicon with multicharge Mn clusters," *Applied Solar Energy (English translation of Geliotekhnika)*, vol. 44, no. 2, pp. 132-134, 2008, [Online]. Available: <https://doi.org/10.3103/S0003701X08020151>.
- [18] E. B. Saitov, Sh. Kodirov, Z. F. Beknazarova, A. Nortoijiyev, and N. Siddikov, "Developing Renewable Sources of Energy in Uzbekistan: Programs and Prospects," *AIP Conference Proceedings*, vol. 2432, 020015, 2022, [Online]. Available: <https://doi.org/10.1063/5.0090438>.
- [19] E. B. Saitov, Y. B. Sobirov, I. A. Yuldoshev, I. R. Jurayev, and Sh. Kodirov, "Study of Solar Radiation and Wind Characteristics in Various Regions of Uzbekistan," *E3S Web of Conferences*, vol. 220, 01061, 2020, [Online]. Available: <https://doi.org/10.1051/e3sconf/202022001061>.
- [20] E. B. Saitov, "Optimal model for additional operation of the storage system for photovoltaic-wind power plants," *E3S Web of Conferences*, vol. 220, 01080, 2020, [Online]. Available: <https://doi.org/10.1051/e3sconf/202022001080>.
- [21] I. Sapaev, E. Saitov, N. Zoxidov, and B. Kamanov, "Matlab-model of a solar photovoltaic station integrated with a local electrical network," *IOP Conf. Series: Materials Science and Engineering*, vol. 883, 012116, 2020, [Online]. Available: <https://doi.org/10.1088/1757-899X/883/1/012116>.